

1500
 c us
 6301099

SÉRIE 30141500
 FEUILLE D'INSTALLATION
 30141500 SERIES
 INSTALLATION SHEET

1. Installation

1. Appuyer et coller le ruban DEL (suivre les guides 10 mm ou 14 mm) dans le profilé. Acceptera un ruban DEL 14 mm de large maximum.*

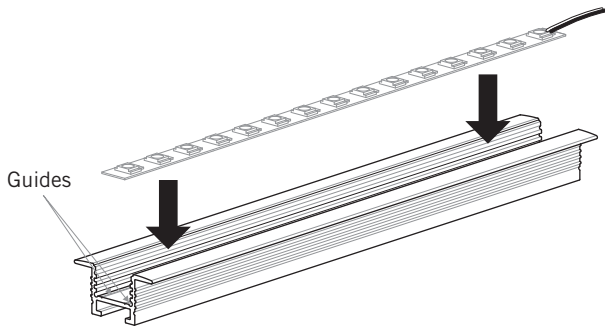

2. Mettre la lentille en place.

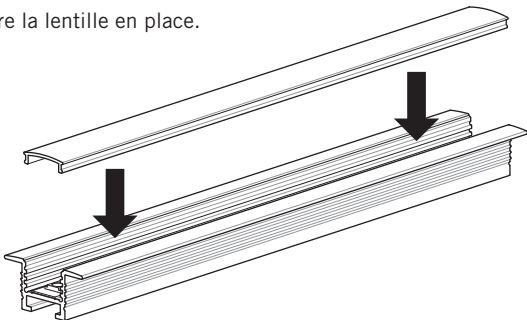

1. Installation

1. Press and glue the LED Strip Tape into the profile (follow 10 mm or 14 mm guides). Will accept 14 mm wide strip maximum.*

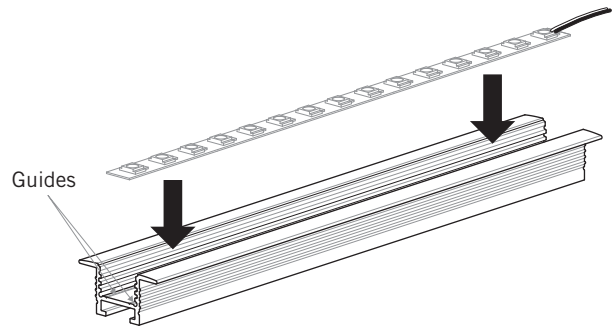

2. Clip the lens into place.

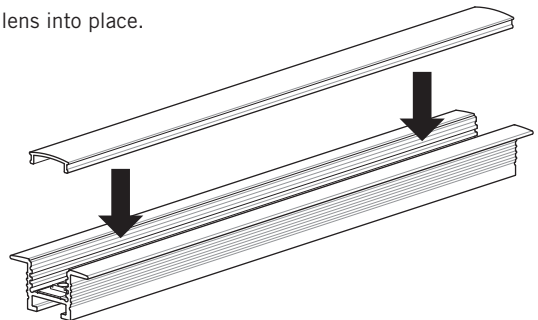

Safe, Fast and Easy to install with the EZLED POWER
 Installation simple et rapide avec le système de connexion
 EZLED POWER



1. Installation

3. Glisser les supports de fixation, puis reserrer les vis.

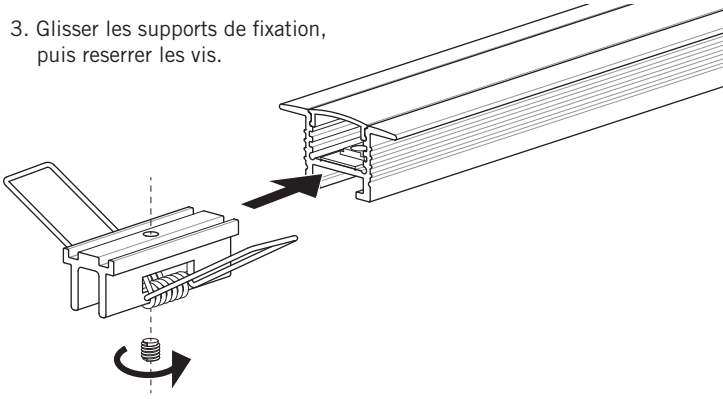

4. Glisser les embouts en place.

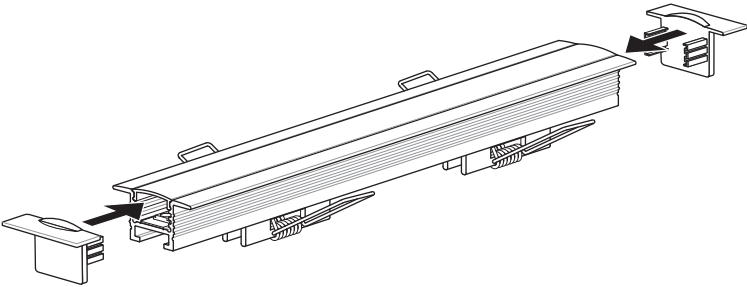

5. Rabattre les bras des fixations en insérant le luminaire dans le trou du mur ou plafond, jusqu'au ras de la surface. Les ressorts vont fixer le luminaire en place.

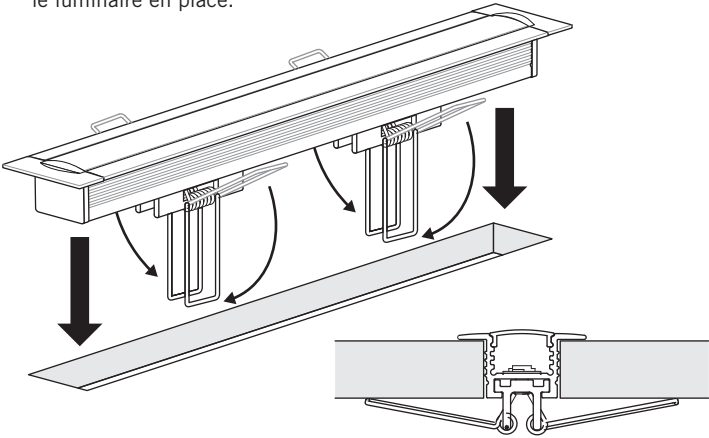

Mise en garde

- Utiliser seulement des composants Certifiées Classe 2 n'excédant pas 30VCC ou 15VAC lors d'une installation dans un endroit mouillé ou 60VCC ou 42.4V ca maximum lors d'une installation dans un endroit sec ou humide.
- Ne pas dépasser 5 ampères pour respecter les normes classe 2.

CLASSE
2

100W
MAX

4 AMP MAX
↓ 24V

5 AMP MAX
↓ 12V

* Les rubans DEL sont vendus séparément.

1. Installation

3. Slide in the mounting brackets, then tighten the lug screws.

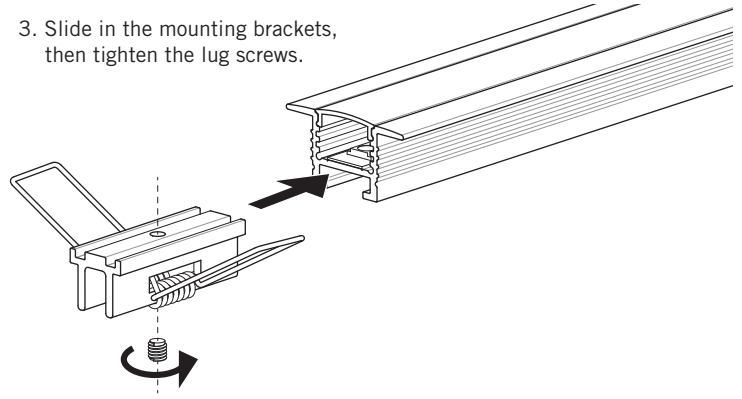

4. Slide the endcaps into place.

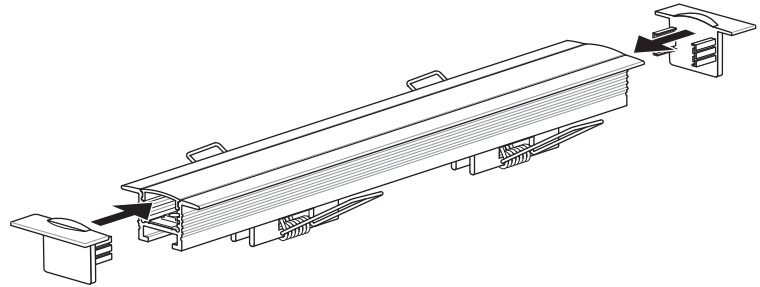

5. Tilt in the bracket arms and pass the lighting fixture through the hole in the wall or ceiling, until flush with surface. The springs will release to secure the fixture in place.

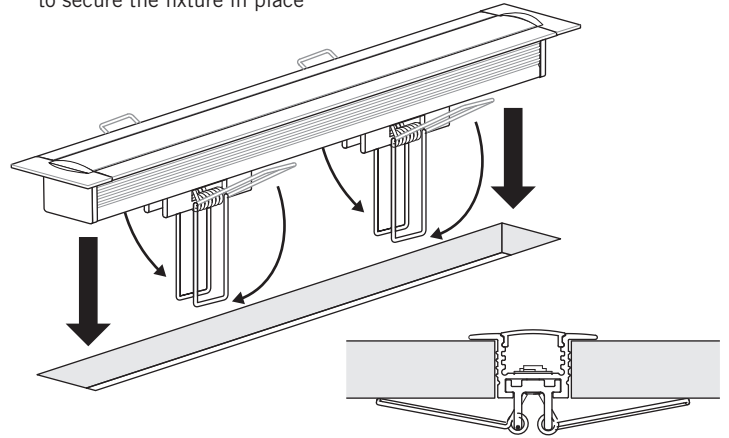

Warning

- Use only Class 2 rated components not exceeding 30VDC or 15VAC when installing the outline lighting in wet locations or 60VDC or 42.4V peak ac when installing the outline lighting in a dry or damp location.
- Do not go over 5 amps to match class 2 requirements.

CLASS
2

100W
MAX

4 AMP MAX
↓ 24V

5 AMP MAX
↓ 12V

* The LED strips are sold separately.