

# SÉRIE LUXSTRUT 9800

## FEUILLE D'INSTALLATION

# LUXSTRUT 9800 SERIES

## INSTALLATION SHEET

**UL** US  
E491159

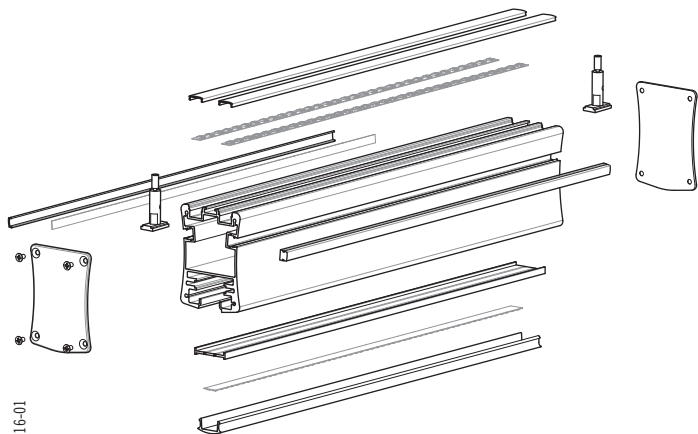

SEPT2016-01

**EZLED**  
POWER

**LUMEN**  
Truss



### Mise en garde / Warning

1. Utiliser seulement des composantes Certifiées Classe 2 n'excédant pas 30V DC ou 15V AC lors l'installation du dispositif d'éclairage dans un endroit humide et 60V DC ou 42.4V AC lors de l'installation du dispositif d'éclairage dans un endroit sec ou humide.
2. Ne pas dépasser 5 ampères pour respecter les normes classe 2.

1. Use only Class 2 rated components not exceeding 30V DC or 15V AC when installing the lighting fixture in a wet location, and 60V DC or 42.4V peak AC when installing the lighting fixture in a dry or damp location.
2. Do not go over 5 amps to match class 2 requirements.

CLASS  
2

100W  
MAX

4 AMP MAX  
↓ 24V

5 AMP MAX  
↓ 12V

**EZLED**  
POWER

Safe, Fast and Easy to install with the EZLED POWER  
Installation simple et rapide avec le système de connexion  
EZLED POWER

**LUMEN**  
Truss

Canadian leader in LED lighting  
Le leader Canadien en éclairage DEL

9221, rue Edison  
Montréal (Québec), H1J 1T4  
1 514 903-5863  
1 855 384-3384  
info@lumentruss.com  
www.lumentruss.com

### 1. Installation

1. Insérer, appuyer et coller les rubans DEL supérieurs (suivre guide de 10mm) et latéraux (optionnel) dans la barre profilée. Acceptera un ruban DEL 14 et 10 mm de large maximum respectivement.\*

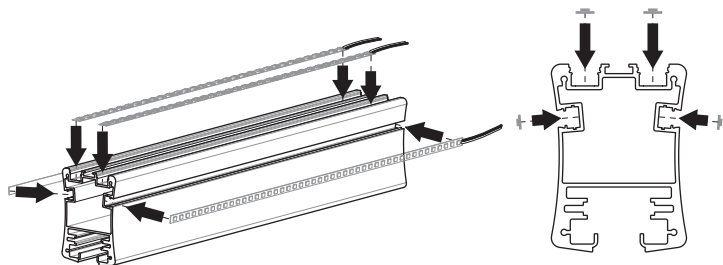

2. Appuyer et coller le ruban DEL inférieur sur le rail. Suivre les guides de 10 mm ou 14 mm. Acceptera un ruban DEL 33 mm de large maximum.\*

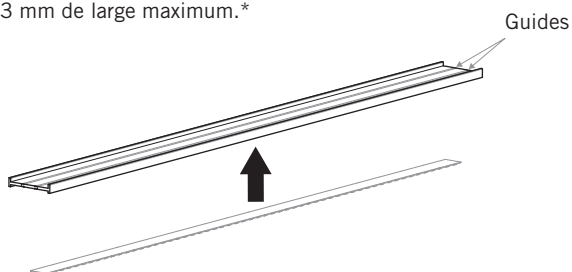

\* Les rubans DEL sont vendus séparément.

### 1. Installation

1. Insert, press and glue the upper LED Strip Tapes (follow 10mm guide) and lateral LED Strip Tapes (optional) into the profiled bar. Will accept a 14 and 10 mm wide strip maximum respectively.\*

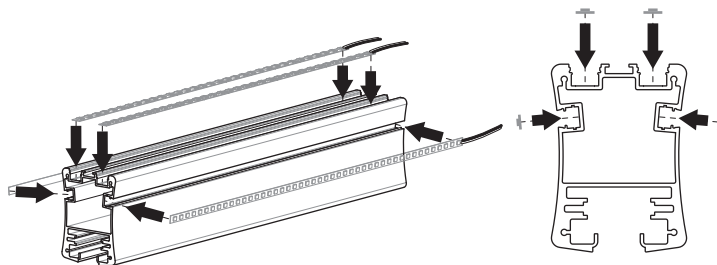

2. Press and glue the lower LED Strip Tape onto the rail. Follow 10mm or 14mm guides. Will accept a 33 mm wide strip maximum.\*

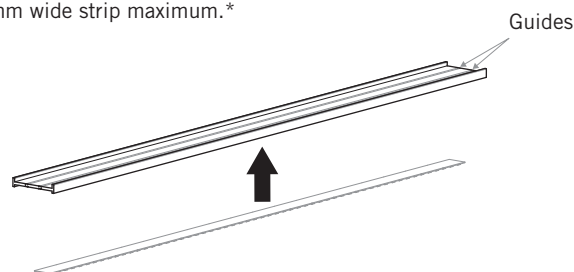

\* The LED strips are sold separately.

## 1. Installation

3. Glisser le rail à l'intérieur de la barre profilée.

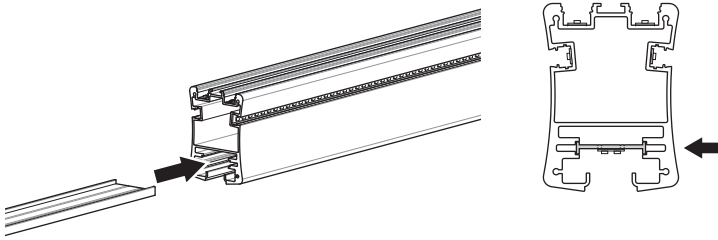

4. Mettre les lentilles en place. Si aucun ruban DEL latéral n'est pas installé, remplacer la lentilles latérales avec panneaux décoratifs (B).

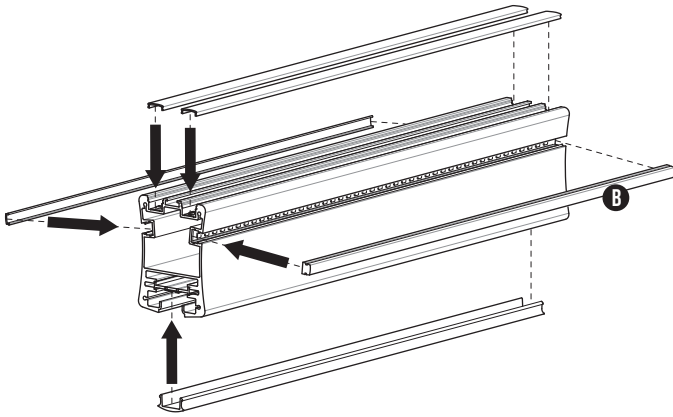

5. Glisser les supports de suspension, puis reserrer les vis.

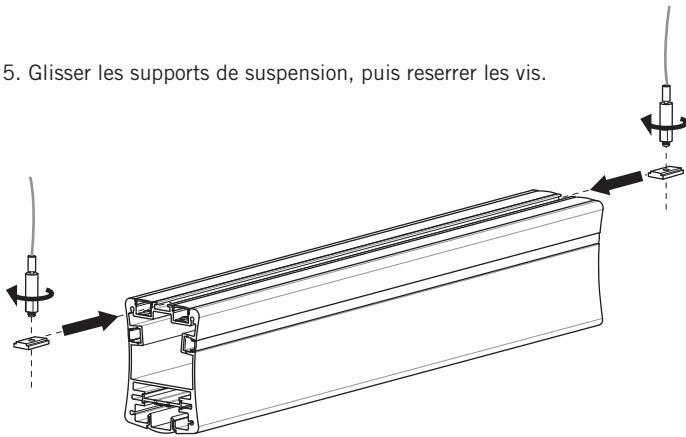

5. Mettre les embouts et les visser en place.

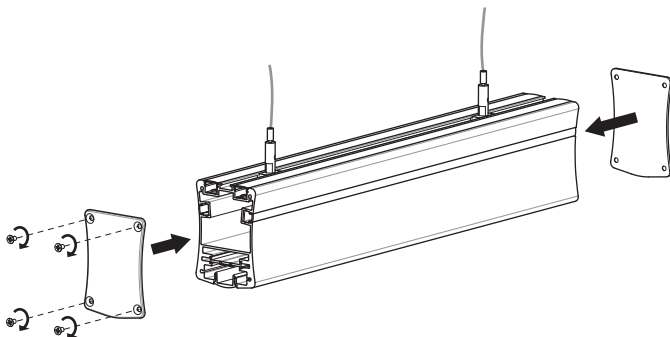

## 1. Installation

3. Slide the rail into the profiled bar.

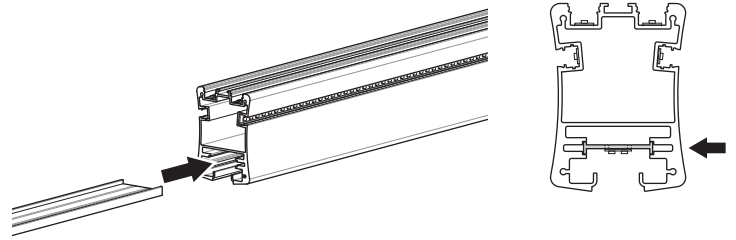

4. Clip the lenses into place. If no lateral LED strip tape has been installed, replace lateral lenses with decorative panels (B).

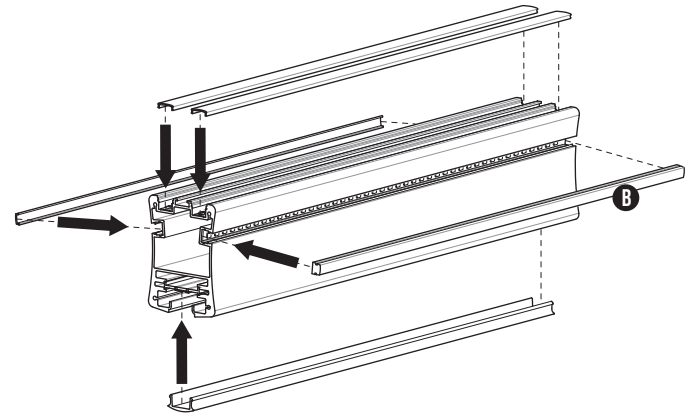

5. Slide in the suspension brackets, then tighten the bolts.

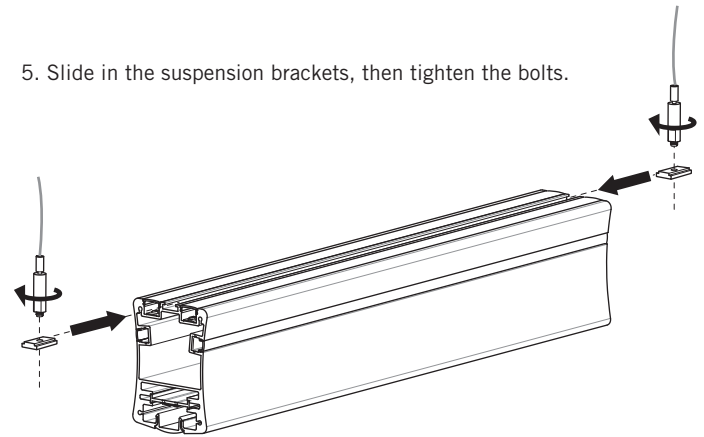

5. Install the endcaps, attach them with screws.

